

BY PROMOVEC

DOWNTUBE 2 BATTERY

SPECIFICATIONS

Rated voltage	36 V
Com. Protocol	RS-485/UART
BMS	Smart BMS
Voltage scope (V)	31 - 42V
Charge mode	CC-CV (Type A Promovec charger)
Operation temperature charge	0°C - 45°C

MOUNTING PARAMETER

Position	Downtube
Weight (kg)	2,6 - 2,7
Controller position	Downtube / center
Charger	Promovec charger, Small circular

MOUNTING

Downtube

See frame catalogue

BATTERY OPTIONS

Part No.	Name	Capacity
50790-BL	DT2	8,8Ah, 36V, 316Wh
50791-BL	DT2	10,4Ah, 36V, 374Wh
50793-BL	DT2	12,8Ah, 36V, 482Wh

TESTS & CERTIFICATIONS

IP	IP 65
Certifications	CE / EN 15194/ ROHS / REACH UN 38,3, MSDS

DIMENSIONS

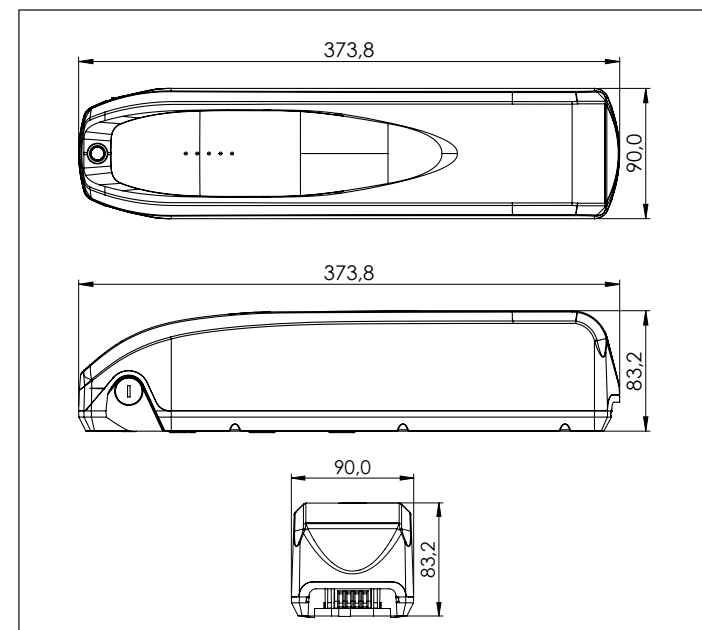

Promovec A/S
Langdyssen 6
DK-8200 Aarhus N

TEL. +45 7027 2623
FAX. +45 7027 2429
MAIL info@promovec.dk

Promovec® 
the e-bike solution