

BY PROMOVEC

# CONTROLLER CARRIER 6-XL

Type **Carrier 6/XL**  
Motor position **Front + rear**

## BATTERY INFORMATION

Battery type **UART**  
Battery communication **Yes**

## SPECIFICATIONS

Voltage **36V**  
Power rating **250W**  
Light output **6V, 0,4 A**  
Brake cut off support **Yes**  
BB pedal sensor type **Speed**  
Display protocol **v1**  
Speed limit **25 km/t**  
Walk-assist **Yes**  
Throttle function **Yes**

## OPTIONS

Wheel size **26", 28", 29"**  
Driving mode **Speed & ECO**

## COMPATIBLE MOTORS

**50080-3, 50275-2,  
50742, 50710, 50704,  
50971, 50609-1-BL,  
50750**

## WIRING

Motor cable **Length: Connector**  
BB sensor cable **Integrated 5 pin circular**  
Display cable **Integrated V1**  
Brake cut off + light cable **Integrated 3-pin circular**

## COMPATIBLE SENSORS

**50960, 50920, 50587**

## COMPATIBLE DISPLAYS

**V1**

## TESTS & SPECIFICATION

IP **IP54**  
Certifications **CE / EN 15194 / REACH / ROHS**

## COMPATIBLE BATTERIES

**50638-BL-C-36V,  
50663-BL-C,  
50774-BL-C-36V,  
50775-BL-C-36V,  
50776-BL-C-36V,  
50789-BL-C-36V**

## DIMENSIONS

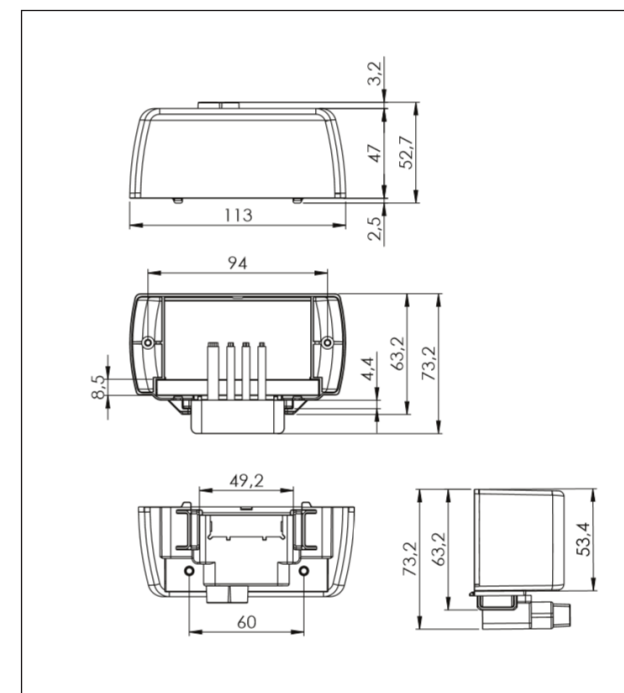

Promovec A/S  
Langdyssen 6  
DK-8200 Aarhus N

TEL. +45 7027 2623  
FAX. +45 7027 2429  
MAIL info@promovec.dk

Promovec®   
the e-bike solution